

FEATURE

- ◆ 1812 size, surface mount type
- ◆ Operation temperature range up to 125°C
- ◆ Products meet applicable automotive industry standards
- ◆ Compliant with AEC-Q200 Rev-D Stress Test Qualification for Passive Components in Automotive Applications
- ◆ Low thermal derating factor
- ◆ Higher hold current

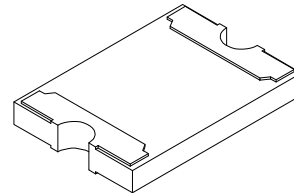

APPLICATIONS

- ◆ Overcurrent surge protection of electronic equipment required to operate at high temperature ranges
- ◆ Resettable fault protection of general electronics equipment
- ◆ Automotive electronics control module protection
- ◆ Industrial control
- ◆ Telematics, infotainment, and navigation systems

ELECTRICAL CHARACTERISTICS

Part Number	I _H	I _T	V _{max}	I _{max}	Max. Time-to-trip		P _{dTyp}	R _{Min}	R _{1Max}
	(A)	(A)	(V)	(A)	(A)	(S)	(W)	(Ω)	(Ω)
1812HPS035-36	0.35	1.75	36	40	8.0	0.10	1.2	0.30	2.60
1812HPS050-30	0.50	2.50	30	40	8.0	0.10	1.2	0.18	1.60
1812HPS075-30	0.75	3.75	30	40	8.0	0.10	1.5	0.09	0.85
1812HPS110-16	1.10	5.50	16	40	8.0	5.00	1.5	0.05	0.45
1812HPS125-09	1.25	6.25	9	40	8.0	5.00	1.5	0.03	0.30
1812HPS150-09	1.50	6.00	9	40	10.0	5.00	1.5	0.022	0.20

I_H = Hold Current. Maximum current device will not trip in 25°C still air.

I_T = Trip Current. Minimum current at which the device will always trip in 25°C still air.

V_{max} = Maximum operating voltage device can withstand without damage at rated current (I_{max}).

I_{max} = Maximum fault current device can withstand without damage at rated voltage (V_{max}).

T_{trip} = Maximum time to trip at assigned current.

P_{dTyp} = Typical power dissipation when device is in the tripped state in 25°C still air environment at rated voltage

R_{min} = Minimum device resistance prior to tripping at 25°C.

R_{1max} = Maximum device resistance is measured one hour post reflow.

THERMAL DERATING CURVES(for reference only)

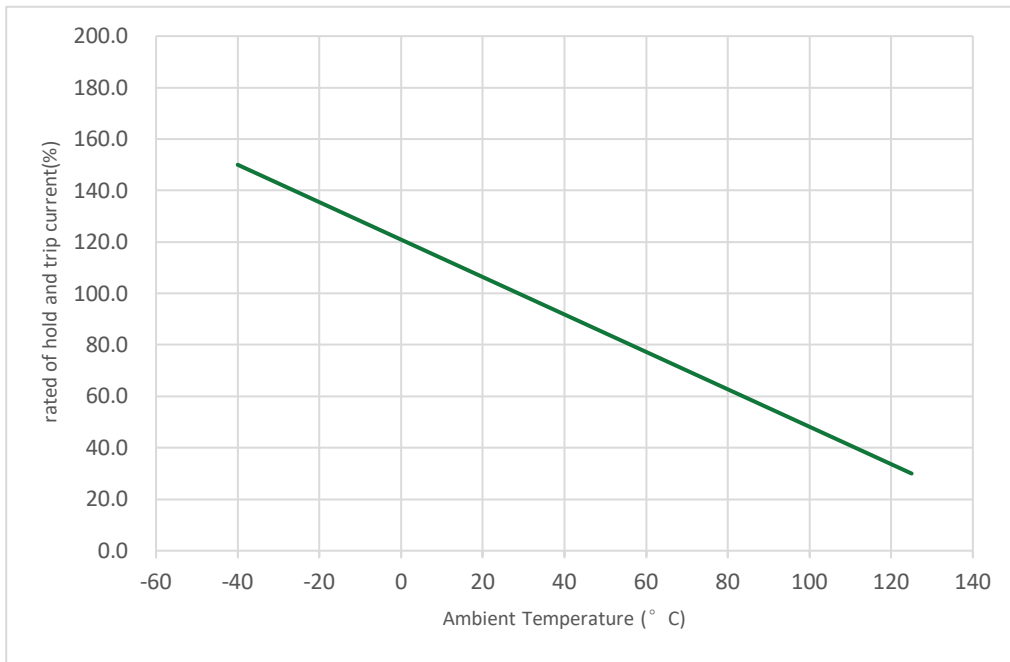

PHYSICAL CHARACTERISTICS

Terminal pad material:	100% Matte Tin with Nickel Underplate
Termination pad	Meets ANSI/J-STD-002, Category 3

REFLOW SOLDERING PROFILE

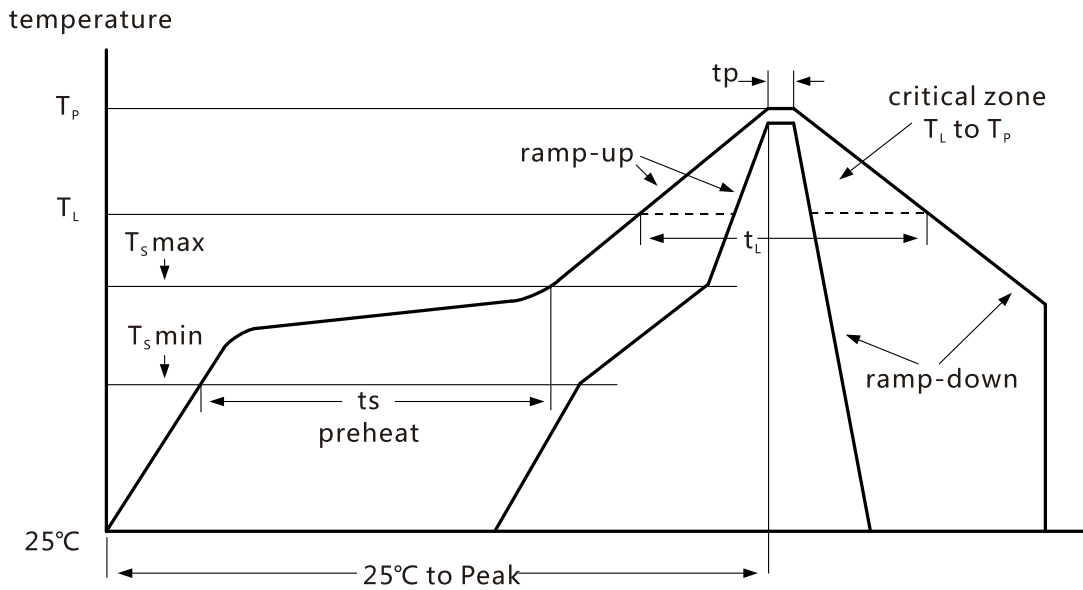

Profile Feature		Pb-free assembly
Average ramp-up rate (T_s max to T_p)		3°C/s maximum
Preheat	Temperature minimum (T_s min)	150°C
	Temperature maximum (T_s max)	200°C
	Time (T_s min to T_s max)	60 s to 180 s
Time maintained above	Temperature (T_l)	217°C
	Time (t_l)	60 s to 150 s
Peak/classification temperature (T_p)		260°C
Time within 5 °C of actual peak temperature (t_p)		20 s to 40 s
Ramp-down rate		6°C/s maximum
Time 25 °C to peak temperature		8 minutes maximum

ENVIRONMENTAL CHARACTERISTICS

Test	Test Conditions	Accept/Reject Criteria
Operating Temperature	-40°C to +125°C	
Recommended Storage	+40°C max/70% R.H. max	
Passive Aging	+125°C, 1000 hours	R<R1max
Humidity Aging	+85°C, 85% R.H., 1000 hours	R<R1max
Thermal Shock	+125°C/-40°C 20 times	R<R1max
Solvent Resistance	MIL-STD-202, Method 215	No change
Vibration	MIL-STD-883C, Method 2007.1 Condition A	No change
Moisture Sensitivity Level	J-STD-020	Level 1

THERMAL DERATING CHART-IH(A)

Recommended Hold Current(A) at Ambient Temperature(°C)

Part Number	Maximum Ambient Temperature									
	-40°C	-20°C	0°C	25°C	40°C	50°C	60°C	70°C	85°C	125°C
1812HPS035-36	0.51	0.46	0.41	0.35	0.31	0.28	0.26	0.23	0.20	0.09
1812HPS050-30	0.75	0.65	0.55	0.50	0.45	0.40	0.35	0.30	0.25	0.15
1812HPS075-30	1.09	0.98	0.87	0.75	0.66	0.61	0.56	0.50	0.42	0.20
1812HPS110-16	1.60	1.44	1.28	1.10	0.97	0.89	0.81	0.74	0.62	0.30
1812HPS125-09	1.81	1.64	1.45	1.25	1.10	1.01	0.93	0.84	0.70	0.34
1812HPS150-09	2.18	1.97	1.74	1.50	1.32	1.22	1.11	1.01	0.84	0.41

PART NUMBERING

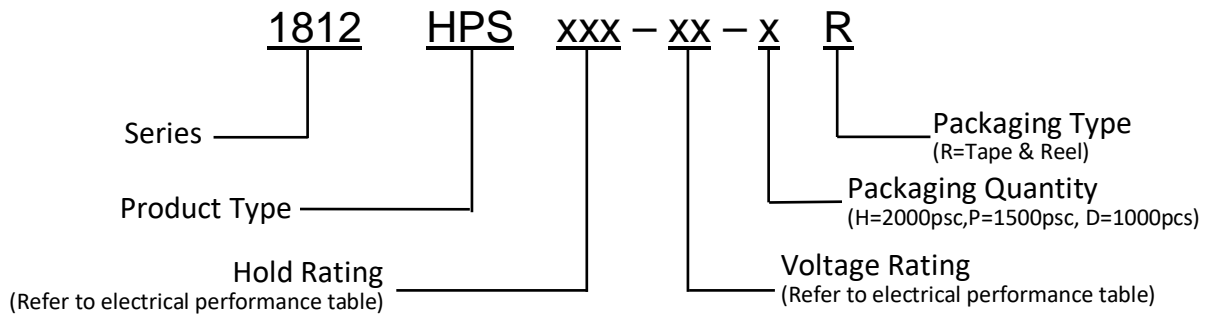

DIMENSIONS & MARKING

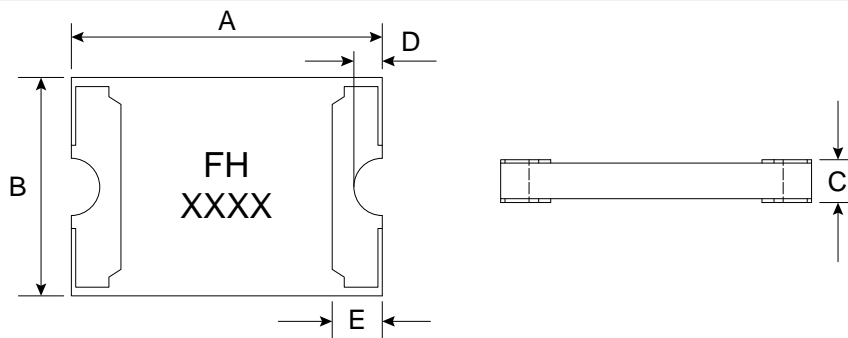

Part Number	Making	Dimension(mm)								
		A(Min.)	A(Max.)	B(Min.)	B(Max.)	C(Min.)	C(Max.)	D(Min.)	E(Min.)	E(Max.)
1812HPS035-36	FH35	4.37	4.83	3.07	3.41	0.40	0.85	0.20	0.25	0.95
1812HPS050-30	FH05	4.37	4.83	3.07	3.41	0.40	0.85	0.20	0.25	0.95
1812HPS075-30	FH75	4.37	4.83	3.07	3.41	0.40	0.85	0.20	0.25	0.95
1812HPS110-16	FH11	4.37	4.83	3.07	3.41	0.60	1.20	0.20	0.25	0.95
1812HPS125-09	FH12	4.37	4.83	3.07	3.41	0.80	1.60	0.20	0.25	0.95
1812HPS150-09	FH15	4.37	4.83	3.07	3.41	0.80	1.60	0.20	0.25	0.95

PADS LAYOUT(recommended) (unit:mm)

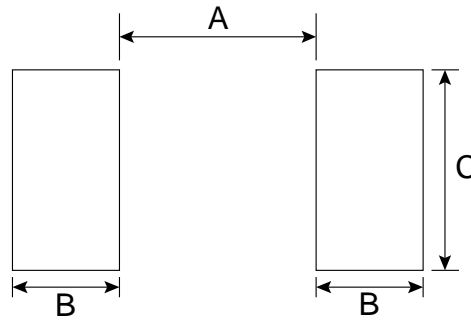

A(Nom)	B(Nom)	C(Nom)
3.10	1.68	3.15

TAPE AND REEL SPECIFICATIONS (unit:mm)

EIA Tape Component Dimensions

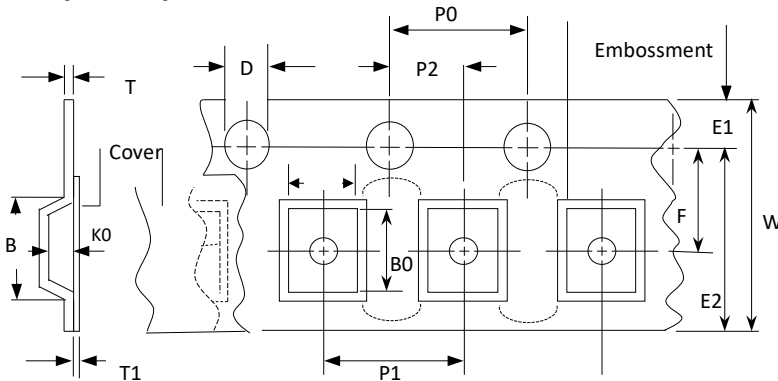

EIA Reel Dimensions

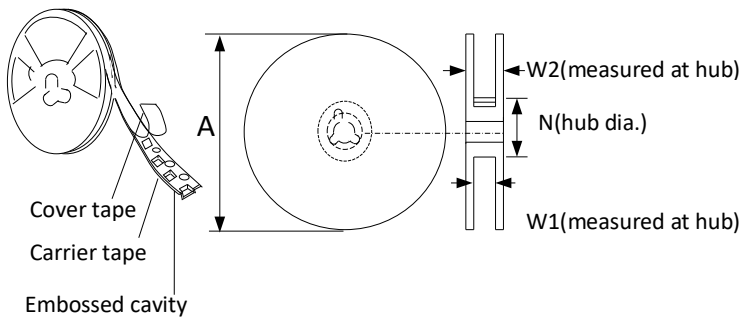

Marking: A label will be attached on the reel and outer box which includes the following items, at a minimum: part name, quantity, lot number, safety approval mark (ul, etc).

Governing Specifications	EIA 481-1
W	12.0 ± 0.30
P0	4.0 ± 0.10
P1	8.0 ± 0.10
P2	2.0 ± 0.05
A0	3.7 ± 0.10
B0	4.9 +0.1, -0.08
B1max.	6.15
D0	1.55 ± 0.05
F	5.50 ± 0.05
E1	1.75 ± 0.10
E2min.	10.25
T	0.35
T1max.	0.1
K0	Below table
Reel Dimensions	
A max.	185
N min.	50
W1	12.4 +0.2, -0.0
W2 max.	18.4

K0(mm)	0.85 ± 0.10	1.05± 0.10	1.40 ± 0.10
Description	1812HPS035-36 1812HPS050-30 1812HPS075-30	1812HPS110-16	1812HPS125-09 1812HPS150-09

PACKAGING QUANTITY

Part Number	Ordering code	Halogen Free	Tape&Reel Quantity	Standard Package	Packaging codes
1812HPS035-36	1812HPS035-36-HR	Yes	2000	10000	HR
1812HPS050-30	1812HPS050-30-HR	Yes	2000	10000	HR
1812HPS075-30	1812HPS075-30-HR	Yes	2000	10000	HR
1812HPS110-16	1812HPS110-16-HR	Yes	2000	10000	HR
1812HPS125-09	1812HPS125-09-DR	Yes	1000	5000	DR
1812HPS150-09	1812HPS150-09-DR	Yes	1000	5000	DR

Specifications are subject to change without notice.